

Slot vacuum chucks

Standard sizes
Adapter mats
Custom made chucks

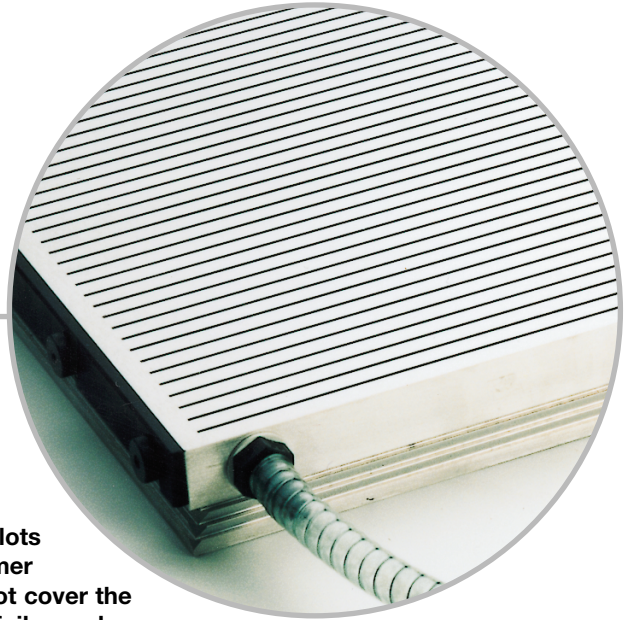

All vacuum slot chucks have integrated slots in their surface area according to customer requirements. To clamp parts, that do not cover the full surface area rubber adapter mats or foils can be used to cover the area not needed under vacuum.

Application

- Light milling work
- Drilling (e.g. semiconductors, electronic parts)
- Engraving
- Also for complicated workpieces

Advantages

- Very flat (28 mm)
- Large range of uses (rubber adapter mat can be reused or exchanged)
- Can be used in High speed cutting for precision work with the aid of the plane parallel black mat that can be machined down to achieve optimum accuracy
- Clamping very small workpieces

Handling

- Makes workpiece positioning easier with the aid of height adjustable end stops
- A limiting of the Vacuum area can be achieved by the moveable hose connection, masking foil or rubber adapter mat. (See page 56 for examples)

Slot vacuum chuck starter set

Slot vacuum chuck with integrated vacuum supply

Item No. 94587

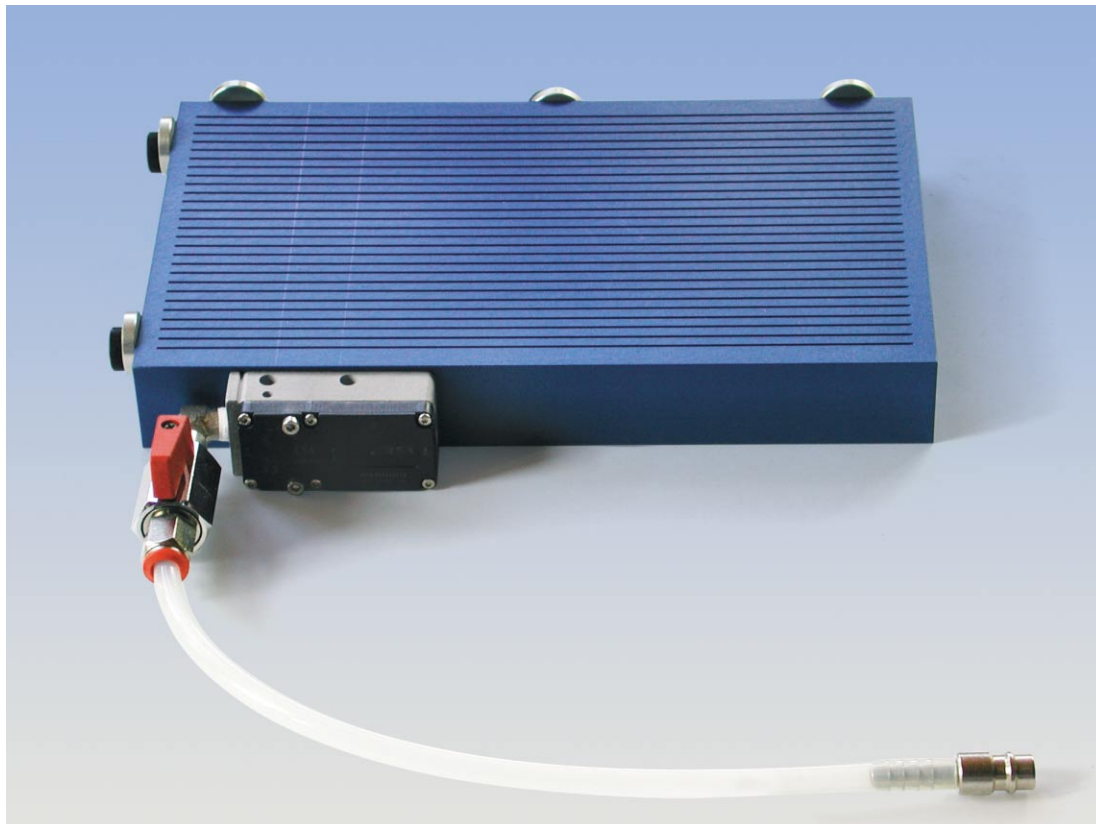

Comprising: Slot - vacuum chuck 32 x 100 x 200 mm in aluminium alloy This chuck already has vacuum supply integrated (see below) and is immediately ready to use. For workpiece adjustment there are excentric stops on two sides of the vacuum chuck. The rubber adapter mat can be configured as required by punching holes through it, thereby enabling clamping of small parts. A vacuum stopper allows limitation of area affected by vacuum thereby extending the clamping possibilities of this vacuum clamping system substantially. It has an oil pressure hose and a plug for commercial pneumatic connection.

Vacuum supply using compressed air Operating pressure of 4-6 bar. Depending upon operating conditions a final vacuum of 940 mbar can be achieved. During vacuum applications 60 litres of air are used. The noise level of approx. 57 dbA. is relatively low but can be reduced further at any time by a suitable muffler from our extensive range of accessories.

Supply includes:

- chuck 32x100x200mm
- 1 vacuum supply (Venturi – injector)
- 2 clamps (#30617) for clamping chuck to machine table
- 1 vacuum stopper
- 1 rubber adapter mat
- 1 Friction booster
- 1 pressure oil hose with connector for compressed air connection

Slot vacuum chucks

Vacuum plate 28mm high

No.	Clamp. area l _x b	Total dim. l _x w _x h	kg
84422	150x100	170x100x28	1,5
84423	200x100	220x100x28	1,9
84424	250x150	270x150x28	3,4
84425	200x200	220x200x28	3,6
84426	300x150	320x150x28	3,9
84427	350x150	370x150x28	4,4
84428	400x200	420x200x28	6,6
84429	350x250	370x250x28	7,5
84430	300x300	320x300x28	7,8
84431	400x250	420x250x28	8,5
84432	400x300	420x300x28	10,2
84433	400x400	420x400x28	13,6
84434	500x300	520x300x28	12,1
84435	600x300	620x300x28	14,4
84388	600x400	620x400x28	19,2

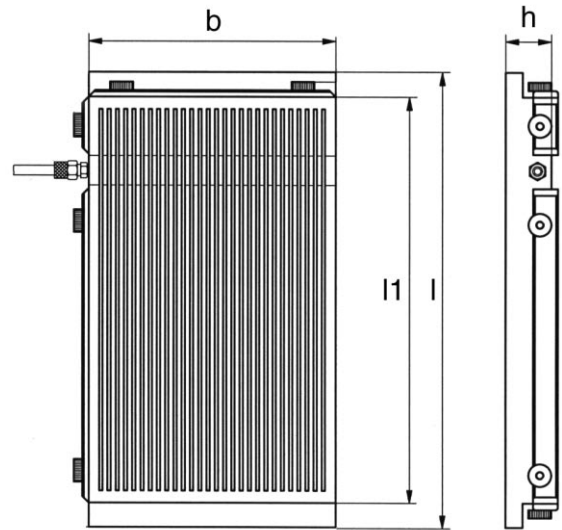

All vacuum slot chucks have a 10mm clamping edge. The slot width is 1mm with a middle distance of 5mm. For the larger plates this may vary to 2mm at 10mm.

Supply includes:

- 1 vacuum chuck
- 1 vacuum stopper
- 1 rubber adapter mat
- 3 height adjustable end stops
- 1m hose with connector for quick coupling



Slot chuck with rubber adapter mat and workpiece

Special dimensions available on request!

Slot vacuum plates

Vacuum plate 38/48mm high

Supply includes:

- 1 vacuum chuck
- 1 vacuum stopper
- 1 rubber adapter mat
- 3 height adjustable end stops
- 1m hose with connector for quick coupling

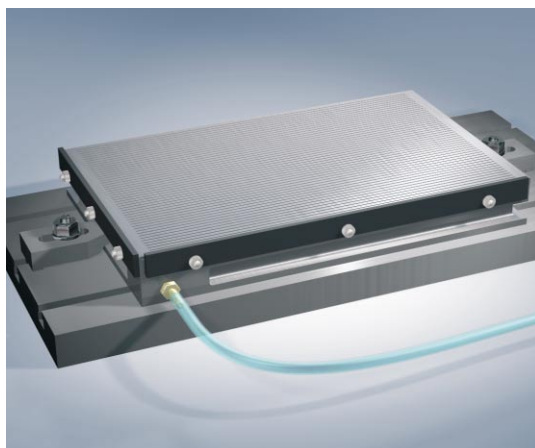

lxwxh (mm)	No.	Aluminium		kg
		s	a	
150x100x38	80016	1	5	1
200x100x38	80017	1	5	2
250x150x38	80018	1	5	3
300x150x38	80019	1	5	4
350x150x38	80020	1	5	5
400x200x48	80021	1	5	8
500x200x48	80022	2	10	13
600x200x48	80023	2	10	15
400x250x48	80024	2	10	13
500x250x48	80025	2	10	16
400x300x48	80026	2	10	15
500x300x48	80027	2	10	19
400x400x48	80130	2	10	21
600x300x48	80028	2	10	23
600x400x48	80136	2	10	31
800x400x48	80029	2	10	41
1000x500x48	80429	2	10	65

No.	Steel		kg
	s	a	
80002	1	5	4
80003	1	5	6
80004	1	5	11
80005	1	5	13
80006	1	5	15
80007	1	5	24
80008	2	10	37
80009	2	10	45
80010	2	10	37
80011	2	10	47
80012	2	10	45
80013	2	10	56
80372	2	10	60
80014	2	10	67
80373	2	10	90
80015	2	10	120
80428	2	10	188

Covering foil

This aluminium foil is a recommended accessory for every slot chuck.

Application:

- cover the chuck completely with the foil
- lay workpiece on to chuck in area nearest vacuum supply
- draw round workpiece
- pierce foil within the contour of workpiece.

All kinds of workpieces can be clamped using this method.

After use the foil is simply peeled off. No rest-adhesive remains on the chuck.

Covering foil. The foil thickness is: 0,06-0,11mm

No.	lxw	pcs.	kg
80269	150x100	400	2,2
80270	200x100	300	2,2
80271	250x150	170	2,2
80272	300x150	140	2,2
80273	350x150	120	2,2
80274	400x200	70	2,2
80275	500x200	55	2,2
80276	600x200	45	2,2
80277	400x250	60	2,2
80278	500x250	45	2,2
80279	400x300	48	2,2
80280	500x300	35	2,2
80445	400x400	32	2,2
80281	600x300	30	2,2
80446	600x400	21	2,2
80282	800x400	18	2,2
80447	1000x500	8	2,2

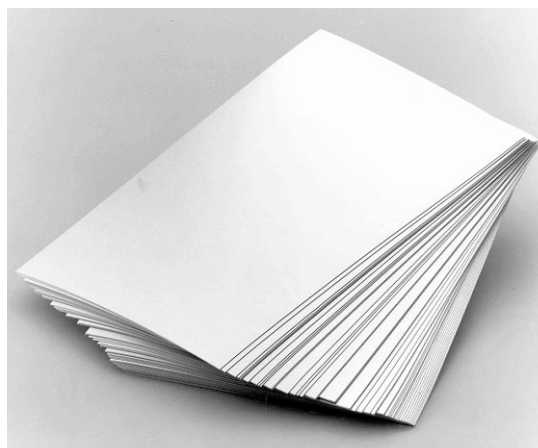

The application is similar to using a rubber adapter mat (see page 48). The difference is that the foil is cut along the slot using a knife. The workpiece should have an even and flat surface for optimal results

Slot vacuum chucks and rubber adapter mat

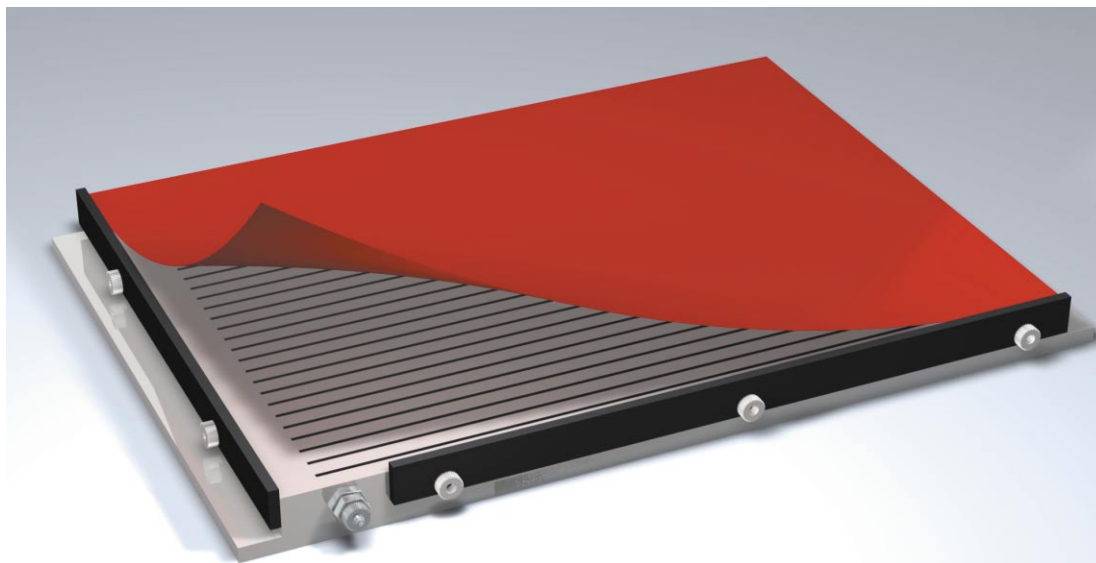

- 1 Lay the rubber adapter mat onto the chuck covering all the slots.**



- 2 Position workpiece with the help of adjustable end stops. Then draw round the contour using an ordinary pen**

Application

Simply follow steps 1-5 and a custom built fixture is ready in seconds. When vacuum is switched on mat and workpiece are sucked down together. The excellent friction values offer especially good resistance to displacement forces during machining.

Using the slot chuck with the rubber adapter mat allows drilling of holes and milling or cutting of pockets and cutouts into the mat to a depth of 1,5mm without losing vacuum. As the mat suffers hardly any wear and tear it can be used often for workpieces with the same contour.

Certain applications allow the tool to work to depths of 1,5mm into the mat.

Height tolerance of the mats lie in the range of $\pm 0,3\text{mm}$.

(DIN 7715, part Kl. P2)

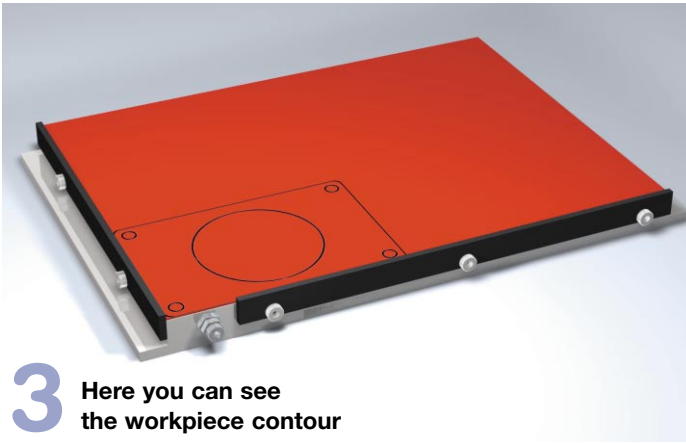

3 Here you can see the workpiece contour

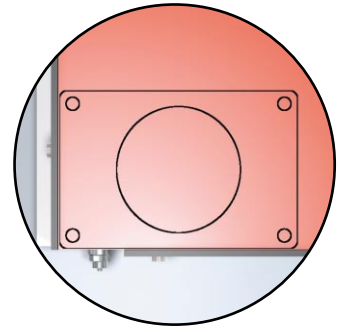

4 Remove the mat and punch holes into the area corresponding to the actual clamping surface of the workpiece. The holes should be approx. 3-8 mm Dia. in a 10mm grid and lie on slots of the chuck

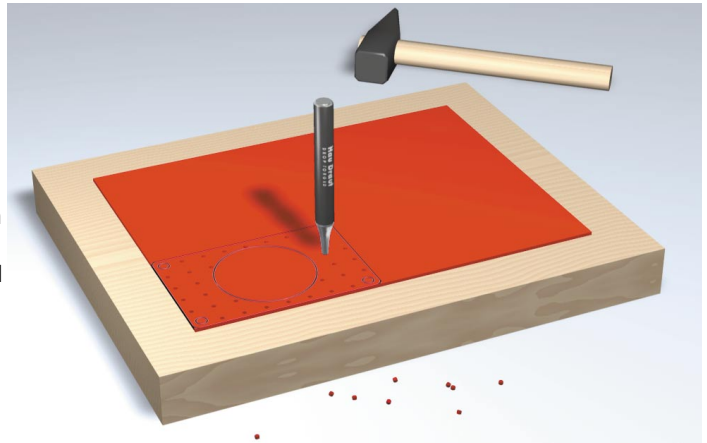

5 Replace workpiece onto the mat. The excellent friction of the rubber material counteracts high-displacement forces better than any other vacuum system.

Rubber adapter mats for slot vacuum chucks

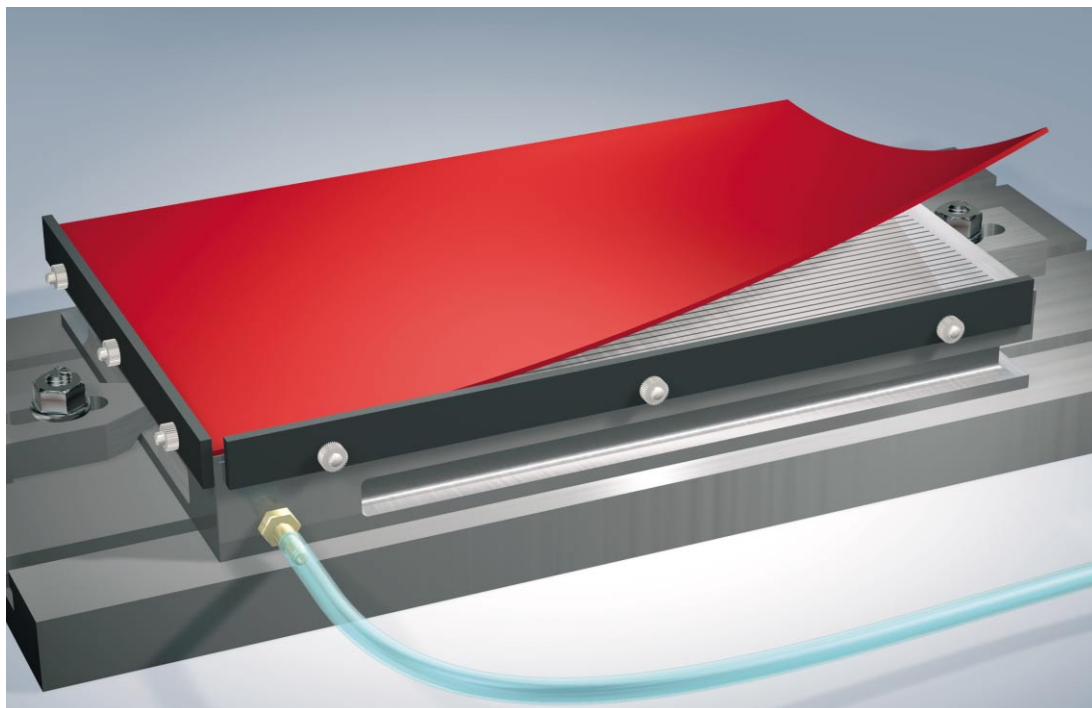

Rubber adapter mats, brown, for use on slot type vacuum chucks (see also page 48)

Brown mats have very high friction properties, low accuracy and cannot be machined (as opposed to black mats).

Dimension tolerance according to DIN 7715 Part 5.

Rubber adapter mats with less tolerance (0,05mm) are available on request

No.	lxwxh
00005	150x100x3
00006	200x100x3
00007	250x150x3
00008	200x200x3
00609	200x500x3
00564	200x600x3
00009	300x150x3
00010	350x150x3
00011	400x200x3
00013	350x250x3
00014	300x300x3
00015	400x250x3

No.	lxwxh
00016	400x300x3
00017	400x400x3
00415	500x300x3
00164	500x500x3
00418	500x1000x3
00437	600x300x3
00414	600x400x3
00409	1000x1000x3
00682	1000x2000x3
00732	1000x2000x1
00733	1000x2000x1,5

Rubber adapter mats for slot vacuum chucks

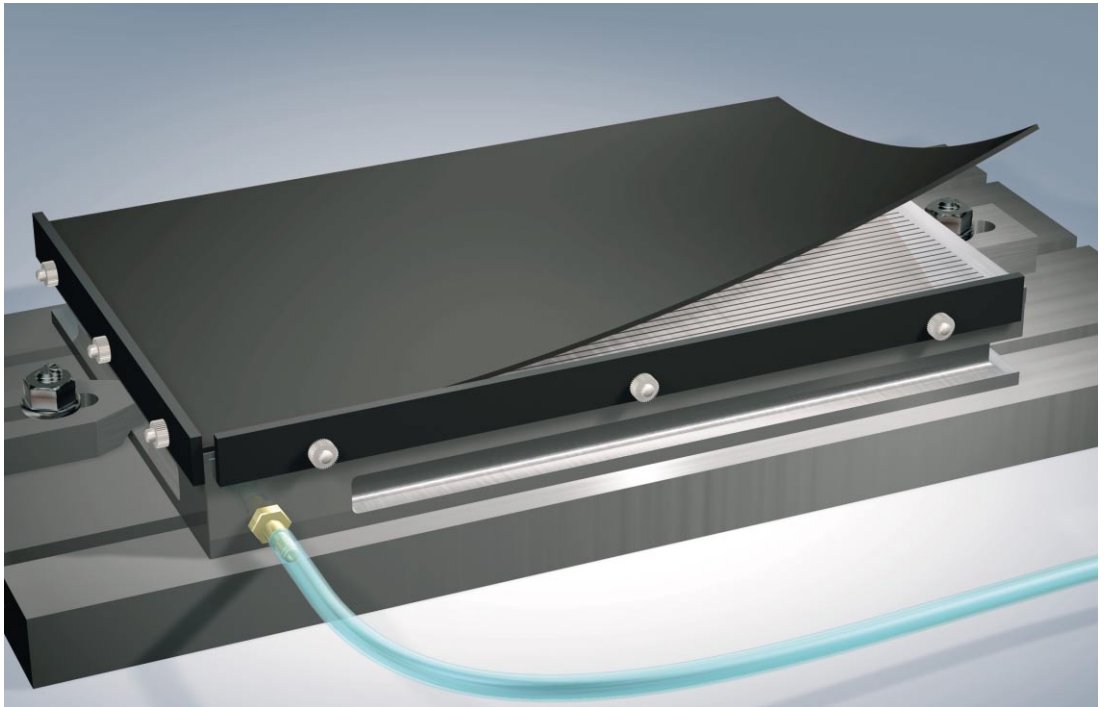

No.	lxwxh
00845	100x150x3
00846	100x200x3
00847	150x250x3
00848	200x200x3
00849	200x500x3
00850	200x600x3
00851	150x300x3
00825	200x400x3
00852	250x350x3
00853	300x300x3

No.	lxwxh
00796	250x400x3
00854	300x400x3
00855	400x400x3
00856	400x500x3
00857	500x500x3
00858	300x600x3
00791	400x600x3
00859	500x1000x3
00860	1000x1000x3
00861	1000x2000x3

Rubber adapter mats, black, made of synthetic polymer for use on slot type vacuum chucks. Black mats have low friction properties and achieve high accuracy (tolerance approx. 0,05mm) after they have been machined by customer directly on their machine.

Slot vacuum chucks - special versions

Slot vacuum chucks for workpieces with complicated geometrical forms, also with cut-outs i.e. screens; ideal for light machining operations like engraving or grinding etc.

The vacuum supply is connected to a moveable hose within the plate. In order to reduce the area affected by vacuum the hose is pulled towards the user and the end sealed with a plastic chip put into the plate between the lines marked.

All slots can be covered also using covering foil (accessories). On the same principle as the rubber adapter mat, the workpiece contour is traced onto the foil. The foil within the contour is then slit using a knife resulting in a custom built fixture in seconds.

By using adapter plates it is also possible to create multiple fixtures



Slot vacuum chuck with special adapter plate

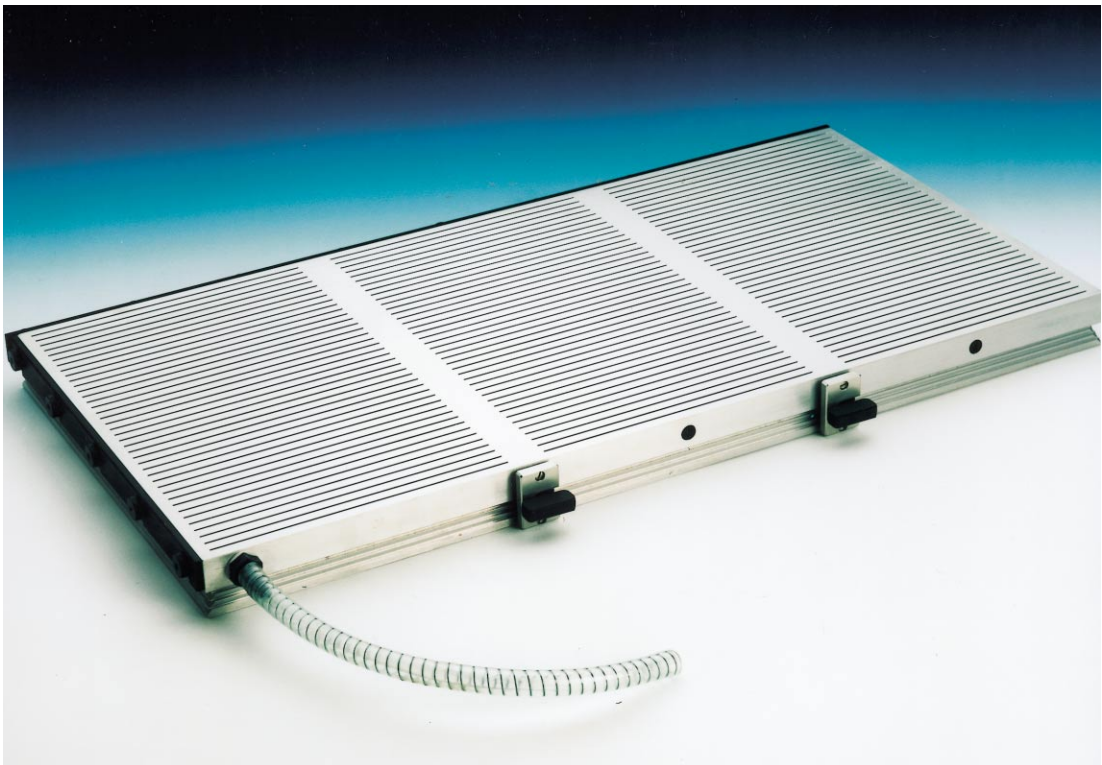

Slot vacuum chuck with 3 vacuum areas, which work combined or independantly